



Menu

## CONTROLLERS



### RC-Bi SERIES: RC-4Bi, RC-7Bi and RC-1260Bi Electromechanical Controllers



#### APPLICATIONS

These controllers are designed to automatically irrigate residential turf areas and athletic fields.

#### FEATURES

- Electromechanical controllers
- Independent station timing knobs
- 14-day calendar dial
- 24-hour clock dial
- Master valve/pump start relay circuit
- ON/OFF switch for rainy weather shutdown
- Manual start capacity
- Indoor wall mount cabinet
- Plastic cabinet with latch to accept padlock
- External transformer
- Easy access to front panel-mounted fuse

#### SPECIFICATIONS

Number of programs: 1  
 Automatic starts per day per program: 23  
 Programming schedule: 14-day calendar  
 Number of stations: 4, 7 or 12  
 Station timing: 3 to 60 minutes in 1-minute increments (RC-4Bi and RC-7Bi models), 6 to 60 minutes in 2-minute increments (RC-1260Bi model)

#### ELECTRICAL SPECIFICATIONS

Input required: 230 VAC - 50Hz  
 Output: 24 VAC - 50 Hz  
 Capacity: 30 VA (1.25 A)  
 Station capacity: 1 RAIN BIRD solenoid valve (24 VAC) per station plus a master valve or pump start relay  
 Master valve output: 24 VAC  
 Fuse: 1.5 A

#### DIMENSIONS

Width: 29.2 cm  
 Height: 20.3 cm  
 Depth: 14.0 cm

#### MODELS

RC-4Bi: 4 stations  
 RC-7Bi: 7 stations  
 RC-1260Bi: 12 stations

#### ACCESSORIES

LPVK-12E: Electrical Surge Protection Kit (see page 79)  
 RAIN CHECK™: Automatic Rain Shutoff Device (see page 78)  
 RSD-BEx : Rain Sensor (see page 78)



# RAIN BIRD RC-4Bi, RC-7Bi, RC-1260Bi SERIES INSTRUCTION MANUAL

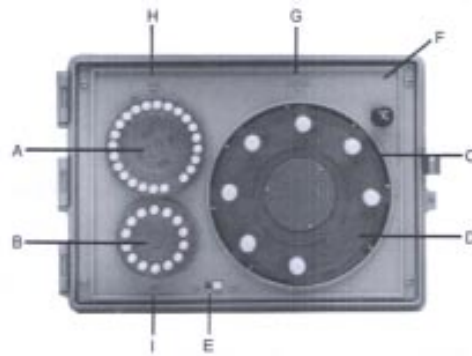

Figure 1

## DESCRIPTION OF CONTROLS

Refer to *Figure 1*

### A. HOUR DIAL with 23 CYCLE START PINS

The HOUR dial contains 23 pins for rescheduling automatic “Starts” on any hour (except midnight which is day changeover time). Embossed characters provide quick identification for each hour, AM or PM, noon and midnight. Captive type pins are designed for simple push-pull operation.

### B. DAY DIAL with 14 SCHEDULING PINS

The calendar DAY dial contains 14 captive pins for scheduling irrigation everyday or any day within a two week range. Each pin represents a 24 period beginning at midnight. Embossed characters are on the dial, adjacent to each day of the week.

### C. STATION SELECTOR / INDICATOR DIAL

The STATION selector / indicator dial contains the timing control (**D**) for each of the stations. The dial automatically rotates during a water cycle with the current station appearing at the top under the station pointer. **REST** indicates the system is off and no watering is taking place. The dial is also used for manual selection of any station for semi-automatic operation.

### D. STATION TIME CONTROL KNOBS

Individual TIME controls for each station. Timing is adjustable up to 60 minutes to suit all landscape growth requirements. A small white arrow moves with each knob along the timing scale on the Station dial (**C**) for visual indication of the time setting. The scale is marked-off in 5 minute graduations and the ratchet action of the knob provides for precision adjustment with each “notch” representing one minute increments. The **OFF** position eliminates the station from the watering schedule. All omitted stations are automatically rapid advanced through the next timed station.

### E. OPERATIONAL MODE SWITCH

The 2-position MODE switch provides the operating control for the system. **AUTO** position for automatic irrigation as schedules and “timed” watering of manually selected station. The **OFF** position is used for rainy weather shutdown. This position eliminates controller “output” to the system valves *without* interrupting the clock operation.

### F. FUSE

1.5 AMP (Slow Blow fuse) protects the controller from damage due to current overload. Replace fuse after the source of trouble has been remedied.

### G. CURRENT STATION INDICATOR

STATION indicator identifies the current position of controller operation. See control (**C**).

## H. CURRENT TIME INDICATOR

**TIME** indicator identifies the current time on the controller clock.

## I. CURRENT DAY INDICATOR

**DAY** indicator identifies the current day of the watering schedule.

## INSTALLATION

The controller's cabinet is suitable for indoor wall mounting. Four mounting holes are provided through the back surface of the cabinet. Before mounting the controller, consider accessibility, electrical power source and connections to the system control valves.

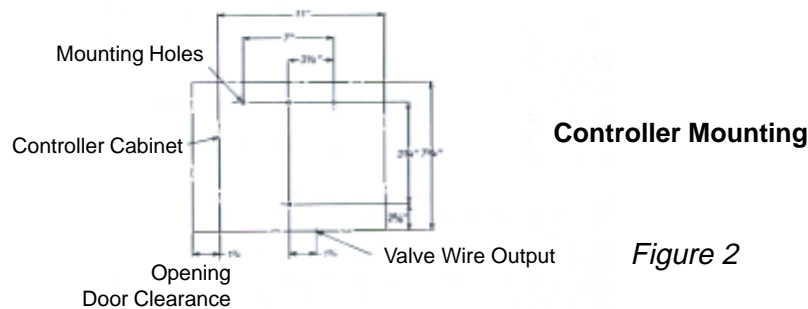

Figure 2

## MOUNTING

1. Choose a location that provides a minimum clearance of 13 " wide x 8" high. Since the electrical connections are provided at the bottom of the cabinet, clearance should be allowed for the conduit connections, etc. Refer to **Figure 2**. The location must be within 5 feet of an electrical outlet.
2. Remove the 4 panel mounting screws, lift out panel carefully.
3. Position the cabinet on the wall at the mounting location, and with a pencil, mark the mounting holes desired (4 holes are provided) on the wall. Two vertical holes are provided for mounting to a wall stud. (Note: Use # 10 screws) .

## ELECTRICAL CONNECTIONS

ALL WIRING MUST BE INSTALLED AND CONNECTED IN ACCORDANCE WITH LOCAL CODES. A basic wiring diagram, with color code identification is provided on the inside surface of the cabinet for easy reference.

A 1/4" diameter hole is provided in the bottom of the cabinet for insertion of the transformer input wire. See **Figure 4**.

The controller transformer provides 24 VAC output for the station valves. The output leads are color coded and stamped with the corresponding station designations. See **Figure 3**.

1. Connect one Lead from each valve to the desired station output lead using wire nuts.

**NOTE:** If the Master Valve / Pump Start circuit is used, connect only one Rain Bird, 2 watt, solenoid valve per station.

2. Connect the second lead from all valves to the white common output lead. Record the valve locations or landscape zone identification for each station on the label inside the cabinet door.

## Valve Output Wiring

OUTPUT LEAD	COLOR CODE
Station 1	Brown
2	Red
3	Orange
4	Yellow
5	Green
6	Blue
7	Violet
8	Gray
9	White
10	White / Blk
11	White / Brn
12	White / Red
Master Valve	Wht / Orn
Valve Common	White
(2) Transformer	Wht / Red Wht / Brown

Figure 3

## Master Valve Wiring

1. Connect one Lead from a 24 VAC Master Valve to the controller Master Valve lead (Wht / Orn.).
2. Connect the other Master Valve lead to the controller common (white) along with the valve common leads.

**CAUTION:** If a master valve is not being used, be sure to tape the end of the Master Valve lead to prevent any possibility of “shorting” .

## CAUTION:

“Dead-Heading” a pump (running the pump’s motor without water flowing through it) may cause pump damage. It may also result in personal injury from hot water spraying from the pump as a result of static water within the pump heating to a temperature where plastic pipe and fittings may melt and discharge the water. ALL CONTROLLERS USING PUMP. START RELAYS ON MASTER VALVE / PUMP START CIRCUITS MAY ENCOUNTER THIS PROBLEM. As a safeguard against such an incident the following procedure is highly recommended.

All UNUSED stations on an electromechanical controller must be connected to a station on the controller where a valve is present if a pump start relay is used to start a pump. This installation method eliminates possible pump dead-heading if station timing is inadvertently programmed on a station where a valve is not present. See details below.

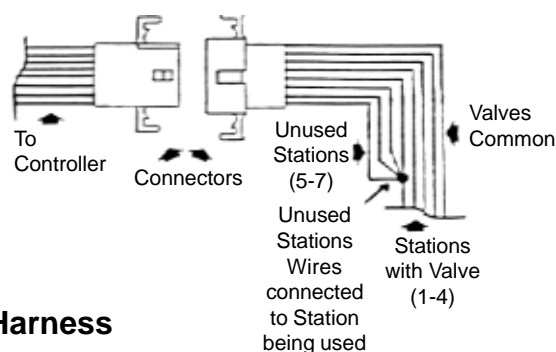

## Controller Using Wire Harness

### Instructions for Attaching Plug-In Transformer.

Prior to connect the transformer into a 230 VAC power source, insert the wire through the ¼" hole in the lower left corner of the controller, tie and overhand knot in the wire about 5" from the end (inside the case). This will prevent disconnecting the wire inadvertently. Connect one orange wire to the wht / red wire with the "line input" label.

See **Figure 4**

Now, connect the transformer to the 230 VAC.

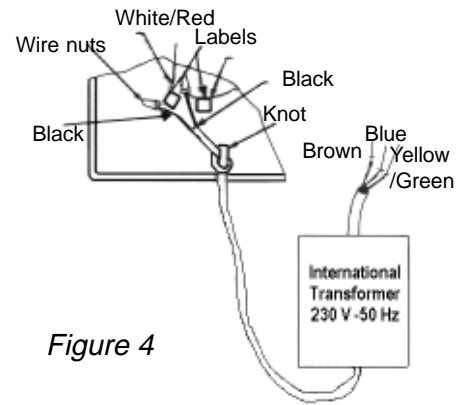

Figure 4

### Electrical System Checkout

1. Rotate the **STATION** dial counterclockwise to position **REST** at the top directly under the station pointer.
2. Pull all pins on the **HOUR** and **DAY** dials to the "out" position.
3. Put the **MODE** switch in the AUTO position.
4. Make sure transformer is plugged into a wall receptacle.
5. Adjust each station **TIME** control to the 5 minute mark. See **Figure 6**.
6. Rotate the **STATION** dial (counterclockwise) to position Station 1 under the pointer.

Watering should commence shortly as the automatic mechanism latches with the Station dial. The 5-minute interval should provide sufficient time to observe control valve operation. If more time is required, simply adjust the timing knobs as necessary. The controller will advance through each station, in sequence, providing opportunity to observe each circuit for proper operation. Upon satisfactory checkout of the system, proceed to adjust the controller clock.

### SETTING THE CONTROLLER

With the main power **ON**, proceed to adjust the clock for the correct time and day.

1. Put the **MODE** switch in the **OFF** position.
2. Rotate the **HOUR** dial (clockwise only) to position the current time opposite the **TIME** pointer at the top of the panel. Observe the dial for the correct AM or PM numerals.

**Example:**

If the correct time is 1: 35 PM, position the dial such that the TIME pointer will point midway between the 1 and 2 numerals on the PM side of the dial. If a more precise adjustment is desired, the best procedure would be to push-in the pin corresponding to the upcoming hour (in this example, the 2 PM) and *on that hour*, slowly rotate the dial until you hear the “click” of the micro-switch.

3. Proceed to set the present day by rotating the calendar **DAY** dial to position the correct letter opposite the **DAY** pointer at the bottom of the dial.
4. Next, rotate the **STATION** dial in a counterclockwise direction to position **REST** at the top under the **STATION** pointer.  
This completes the controller clock setting.

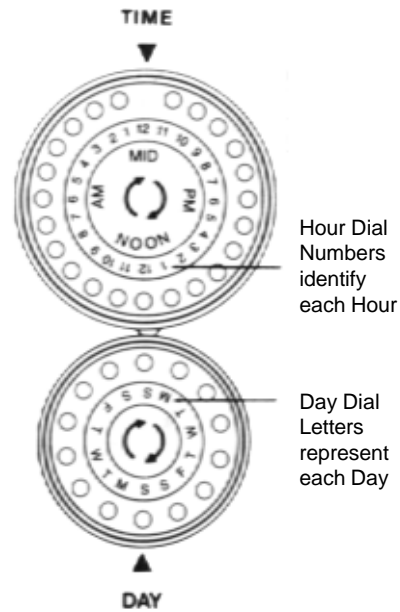

Figure 5

**SCHEDULING AUTOMATIC OPERATION**

Make sure the **HOURL** and **DAY** dials are set to the correct time and that all pins are in the “out” position.

1. Push in the pin(s) corresponding to the day(s) on which watering is desired. Remember, each **DAY** pin represents a 24 hour period beginning at midnight.
2. Next, select the desired starting time(s) and push in the corresponding pin(s) on the **HOURL** dial.
3. the first mark (square dot on the station dial) is the minimum time setting and represents approximately 3 minutes. The small white arrow moves with the knob for visual indication of each setting. (There will be no valve output when the arrow is positioned between “off” and the “square dot”). The ratchet notches represent 1 minute increment settings. The **OFF** position at each timing dial omits the station from the schedule.

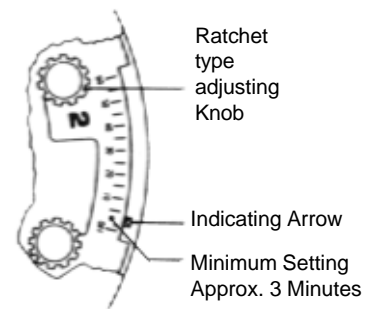

Figure 6

**NOTE:**

The minimum accumulated cycle time required to *prevent* a second start within a given hour is 20 minutes. Conversely, the maximum accumulated time to *permit* a cycle start on a consecutive hour is 55 minutes. Total cycle time of more than one hour is permissible.

**NOTE:** It takes about 20 minutes for the hour dial pin that started a watering cycle to move off the cycle-start switch behind the face panel. To make sure the RC-4Bi will not start another cycle when the combined running time of stations 1 through 4 is less than 20 minutes, the controller will stop at the non-existent station #6 position and time out 20 minutes before returning to “**REST**”.

This completes the automatic setting of the controller. Move the **MODE** switch to the **AUTO** position. The controller will now automatically control the landscape irrigation according to the schedule.

## SEMI-AUTOMATIC OPERATION

The controller may be operated at any time in a semi-automatic mode simply by turning the **STATION** dial counterclockwise to position the desired station at the top, just *ahead* of the Station pointer. Allow the automatic mechanism to advance into the desired timing zone. The selected station will operate for the time set on the dial, after which, the remaining stations will follow in sequence until the **REST** position again appears under the Station pointer.

## RAIN SHUTDOWN

The temporary shutdown of the system is accomplished by moving the **MODE** switch to the **OFF** position. This eliminates controller output to the valves without interrupting the controller timing circuitry. The controller will not operate either automatically or semi-automatically.

A summary of the operating instructions is provided on the label inside the controller door.

## MAINTENANCE

This controller requires no preventative or lubrication. Should trouble occur, refer to the Troubleshooting chart, or contact your local authorized Rain Bird dealer.

### TROUBLESHOOTING CHART

Difficulty	Possible Cause	Remedy
Clock stopped	<ul style="list-style-type: none"> <li>a. Blown fuse</li> <li>b. No power to controller</li> <li>c. In the RC-4Bi, the station dial may be in the 20-minute pause position between station 4 and rest.</li> </ul>	<ul style="list-style-type: none"> <li>a. Replace fuse. If controller stops again, check system circuits to locate trouble</li> <li>b. Check line voltage and connections at each end.</li> <li>c. Let controller time out for 20-minute and return to "REST" automatically.</li> </ul>
DAY and HOUR dials function incorrectly	<ul style="list-style-type: none"> <li>a. Clock set for incorrect time.</li> <li>b. Pins incorrectly set.</li> </ul>	<ul style="list-style-type: none"> <li>a. Reset clock for the "present" time.</li> <li>b. Check pin settings and "accumulated" cycle time on station dial.</li> </ul>
DAY and HOUR dials function, but cycle will not start automatically	<ul style="list-style-type: none"> <li>a. MODE switch in wrong position</li> </ul>	<ul style="list-style-type: none"> <li>a. Move switch to AUTO position.</li> </ul>
Controller recycles immediately without stopping in the REST position.	<ul style="list-style-type: none"> <li>a. Insufficient cycle time allowed.</li> <li>b. Total cycle time coincides with a succeeding START pin.</li> </ul>	<ul style="list-style-type: none"> <li>a. Adjust cycle time to more than 20 minutes.</li> <li>b. Reset the hour pins or readjusting the accumulated cycle time.</li> </ul>
Some stations do not operate.	<ul style="list-style-type: none"> <li>a. Station time set at OFF.</li> <li>b. Faulty valve wiring .</li> </ul>	<ul style="list-style-type: none"> <li>a. Set TIME control for more than 3 minutes.</li> <li>b. Check connections between controller and valves. Also check valve actuators.</li> </ul>
Station dial does not stop at "Timed" station	<ul style="list-style-type: none"> <li>a. Insufficient time set on dial.</li> </ul>	<ul style="list-style-type: none"> <li>a. Adjust the TIME control for more than 3 minutes.</li> </ul>